

35007 35mm平脚限温阀芯

35mm flat base with hot water limiter cartridge

阀芯技术参数

Technical Characteristics of The Cartridge

开启角度：23° 旋转角度：90° 最高使用温度：90°C
 Max On/Off angel : 23° Max Cold/Hot turning angel : 90° Max temperature : 90°C

建议锁紧力矩：10~15Nm 冷热操作力矩：0.2~0.4Nm (任何水温)

Tightness of hex nut torque : 10~15Nm

Cold / Hot operation torque : 0.2~0.4Nm
 (Under any water temp)

开关操作力矩：0.15~0.35Nm (任何水温)

On/Off operation torque : 0.15~0.35Nm
 (Under any water temp)

阀芯破坏强度：≥12Nm

Broken torque : ≥12Nm

爆破压：≥35bar

Burst pressure : ≥35bar

3bar水压下流量值：≥24L/min

Flow rate at 3bar : ≥24L/min

寿命测试：EN817:2008 280,000cycles
 ASME A 112.18.1-2008 2,000,000cycles

Life cycle test : EN817:2008 280,000cycles
 ASME A 112.18.1-2008 2,000,000cycles



认证

Certification



Certified to NSF/ANSI 61-G

DVGW/KTW



ACS

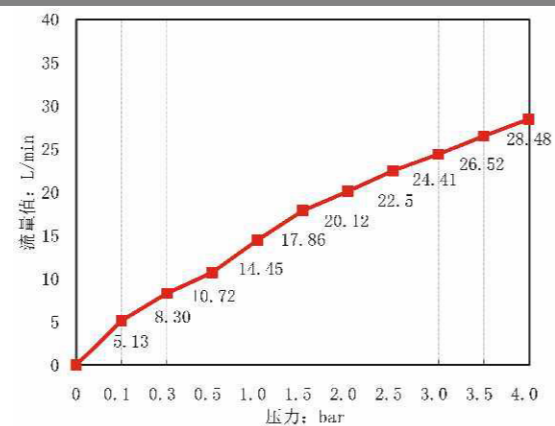

流量图
Flow Rate Curves

限温

With hot water limiter

满足您对水龙头安全舒适的用水需求
 In YJ Cartridge we make cartridges right

安装尺寸图

Drawings of Mounting Dimensions

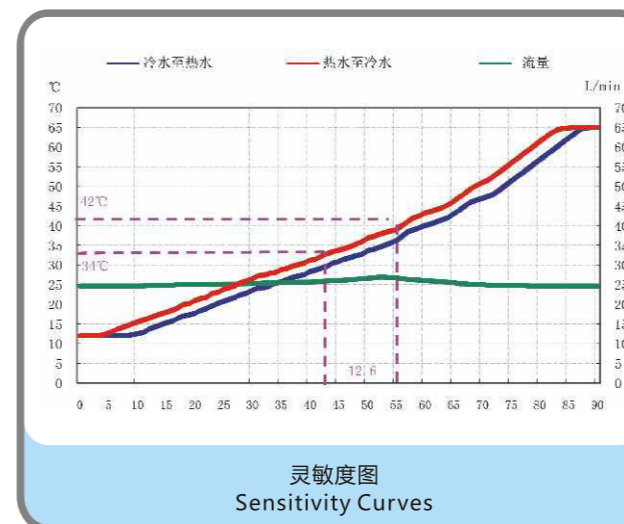
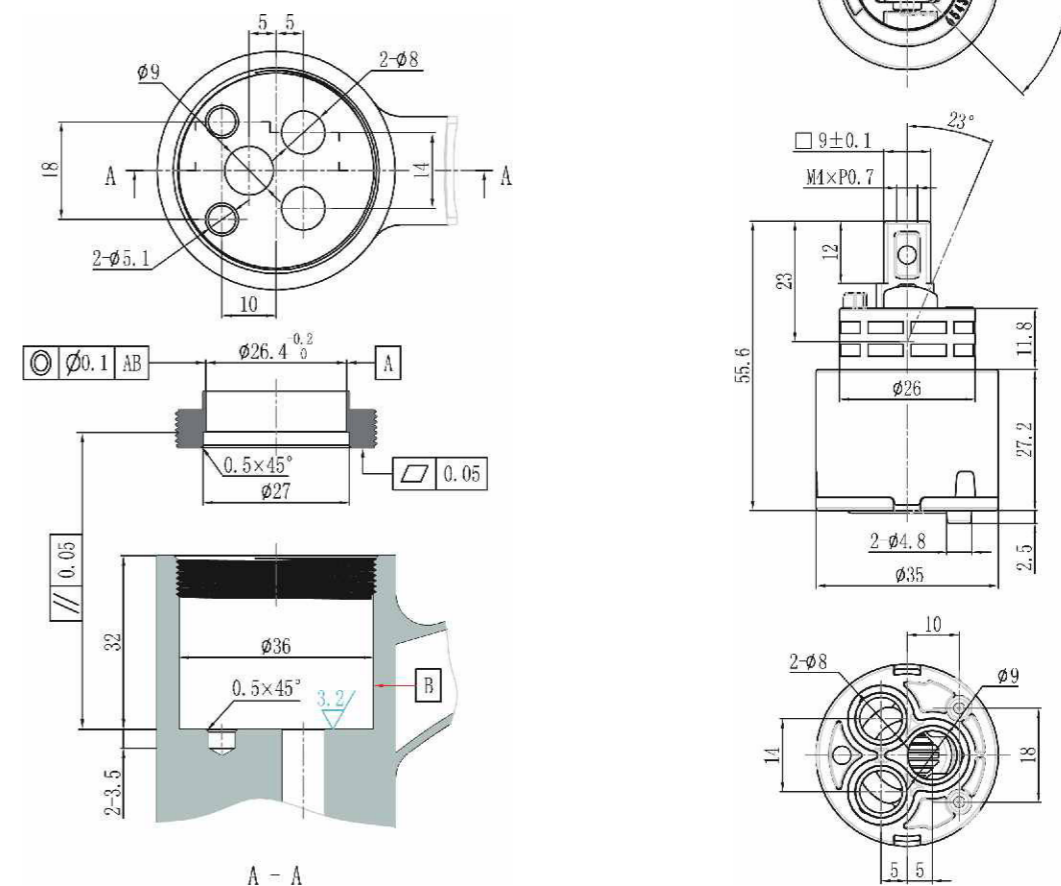

灵敏度图
Sensitivity Curves

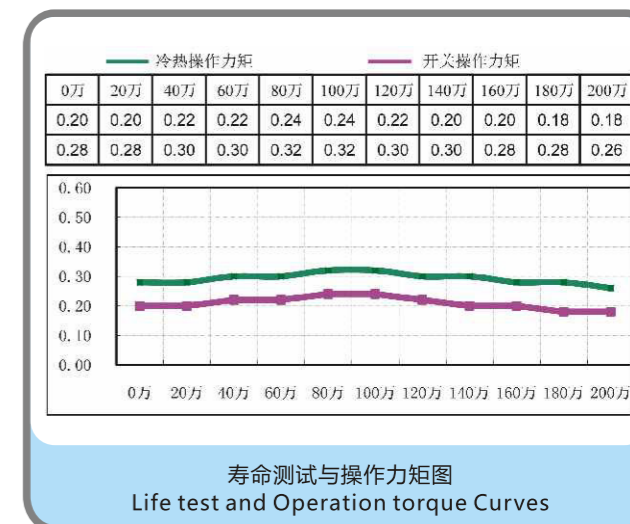

寿命测试与操作力矩图
Life test and Operation torque Curves